



We have worked extensively throughout the industry for over 40 years, and there is no other company in the trade with our working knowledge of Starter Motors, Alternators and Dynamos for Classic and Vintage applications.

Our vast experience in this field has enabled us to develop unique solutions for classic car enthusiasts, supplying an extensive range of up rated units for a wide range of applications and uses.

POWERLITE FITTING INSTRUCTIONS

NEGATIVE EARTH DYNALITE



Lightweight Alternators



Control Boxes



High-Torque Starter Motors



Slimline Starters



Pulleys and Fans



Fitting Accessories

IMPORTANT

CAREFULLY READ ALL INSTRUCTIONS BEFORE FITTING THE UNIT.
FAILURE TO FOLLOW THE INSTRUCTIONS MAY RESULT IN DAMAGING THE DYNALITE UNIT.

Ensure the main alternator cable from battery is rated 60amps minimum



LUCAS TYPE UNITS

FOR POWERLITE REFERENCES:
RAC008

POWERLITE

Moor Street, Brierley Hill, Dudley, West Midlands,
DY5 3SU, ENGLAND
www.powerlite-units.com

ABOUT:

The Powerlite Dynalite is an alternator conversion, providing the benefits of an alternator with the look of a dynamo. The Dynalite unit is identical in fitting to your original dynamo, however unlike your dynamo the Dynalite is a self regulating alternator meaning that the existing control box is no longer required to regulate the Dynalite. Some wiring changes **must** be made. The changes can be made at the existing control box as described below.

FITTING:

1. Disconnect Battery
 2. Exchange your existing Dynamo for your new Dynalite transferring your existing fan and pulley.
- Wiring changes at the voltage regulator: (See opposite for appropriate diagram). A wiring diagram for the vehicle will aid identifying the wires.
3. Disconnect the earth from the control box.
 4. Remove field lead (F) and warning light from regulator (Small wire at D terminal) and attach together.
 5. Remove dynamo lead (D) from regulator and attach to battery positive lead to create a battery feed. (Main alternator feed to battery must be rated at 40 amps minimum.)
 6. Carefully check all wiring, re-connect battery and test.

NOTE:

- Ensure your Dynalite has a good earth, particularly if the vehicle has been recently painted.
- Dynalites **must** run with a cooling fan, original dynamo fans are acceptable.
- If in doubt contact a qualified auto electrician.
- Dynalites perform best with a 2:1 pulley ratio. It may be necessary to use a smaller pulley on low revving engines.
- Ensure all wiring is rated at 40Amps minimum.



RB106



RF95



RB340



RB310

DYNALITE

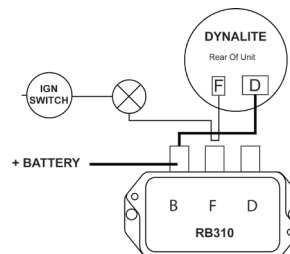
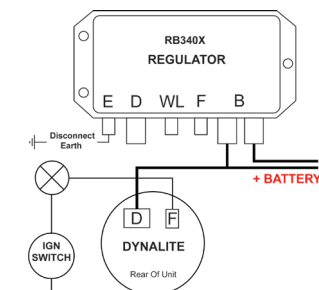
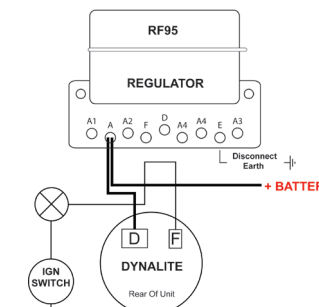
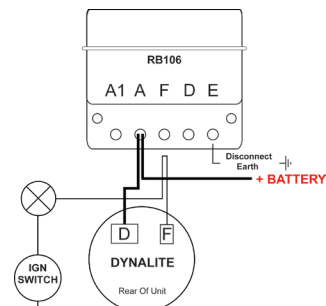

DYNAMO

