



# POWERLITE FITTING INSTRUCTIONS

## DYNALITE and LUCAS RF95 DUMMY CONTROL BOX

### IMPORTANT

CAREFULLY READ ALL INSTRUCTIONS BEFORE FITTING  
THE UNIT.

FAILURE TO FOLLOW THE INSTRUCTIONS MAY RESULT IN  
DAMAGING THE DYNALITE UNIT.

### NOTE:

- Ensure your Dynalite has a good earth, particularly if recently painted.
- Dynalites **must** run with a cooling fan, original dynamo fans are acceptable.
- Dynalites perform best with a 2:1 pulley ratio. It may be necessary to use a smaller pulley on low revving engines.
- If in doubt contact a qualified auto electrician.



LUCAS TYPE UNITS

# NEGATIVE EARTH

## FITTING:

1. Disconnect Battery
  2. Exchange your existing Dynamo for your new Dynalite transferring your existing fan and pulley.
  3. Remove the existing control box and clearly mark the wires.
  4. Fit the new control box carefully replacing all the wires in the same positions, **except** the wire from the warning light, originally located on the D terminal.
  5. Fit the warning light feed wire to the F terminal.
  7. Carefully check all wiring, re-connect battery and test.
- All wires from the Dynalite to the battery must be rated to at least 40Amps.

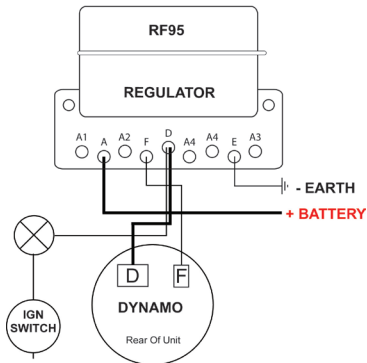

**DYNAMO**

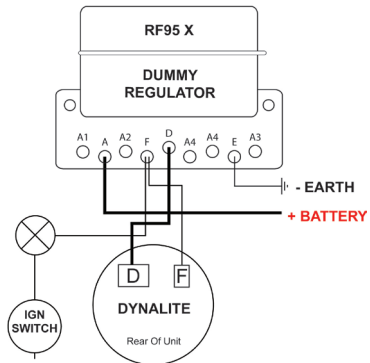

**DYNALITE**

# POSITIVE EARTH

## FITTING:

1. Disconnect Battery
  2. Exchange your existing Dynamo for your new Dynalite transferring your existing fan and pulley.
  3. Remove the existing control box and clearly mark the wires.
  4. Fit the new control box carefully replacing all the wires in the same positions, **except** the wire from the warning light, originally located on the D terminal.
  5. Fit the warning light wire to the F terminal.
  6. All positive earth units are supplied with a relay, this is part of the positive earth Dynalite installation. This **MUST** be fitted between the ignition warning light and ignition switch as shown. Failure to instal this unit will result in instant failure of the Dynalite.
  7. Carefully check all wiring, re-connect battery and test.
- All wires from the Dynalite to the battery must be rated to at least 40Amps.

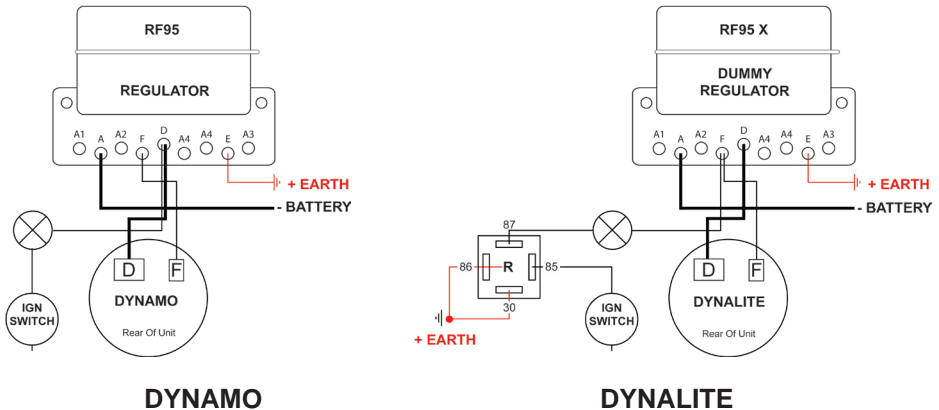

## Relay Wiring Diagram:

