

High Torque Starter Motors

RAC508

Direct replacement for original. For Porsche 911 with a G50 gearbox, please see RAC508A

Porsche 911 1963-89, 912, 914,930,959 Strong, powerful, offset gear-reduced starter motor, delivering huge cranking torque through a set of steel internal gears. Lightweight, compact and durable this unit starts the engine faster with immense power, whilst drawing less current from the battery. For Porsche 911 with a G50 gearbox, please see RAC508A

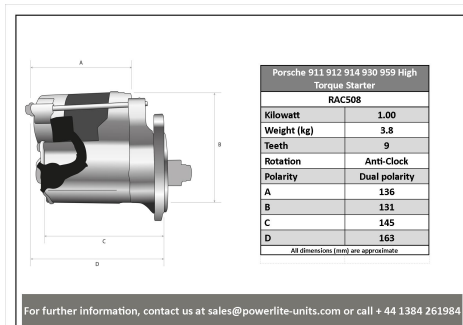
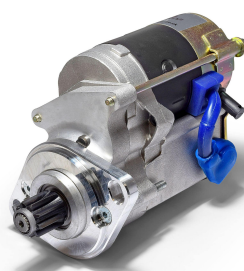
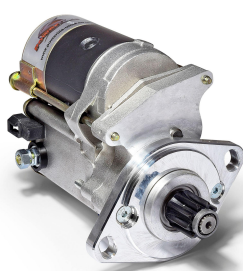

RAC508

Item	Value
Kilowatts	1.00 kW
Teeth	9
Voltage	12 V
Weight	3.80 kg